

Silverline self-locking roller / Electric
 The reflecta large projection screen to be fixed permanently to a wall or ceiling is mounted to an aluminum profile case and is operated either manually or motor-driven. The projection screen is extended and retracted with a space-saving and silent tube motor with integrated end position switch. With the switch, the screen can be stopped at any desired position. Optionally, the screen can be equipped with a locking mechanism to stop the screen at intermediate heights to adjust to different projection formats. Ideal for the training and communications sector.

Product details:

- Mounted to wall or ceiling.
- Electric or manual operation.
- Simple installation and easy handling.
- 8.5 cm x 8.5 cm large tube allows for space-saving installation.
- Large viewing angle.
- Suitable for all common front projection types.
- High-quality screens available in UltraLux (1.2 gain) or RearPro (1.6 gain) quality.

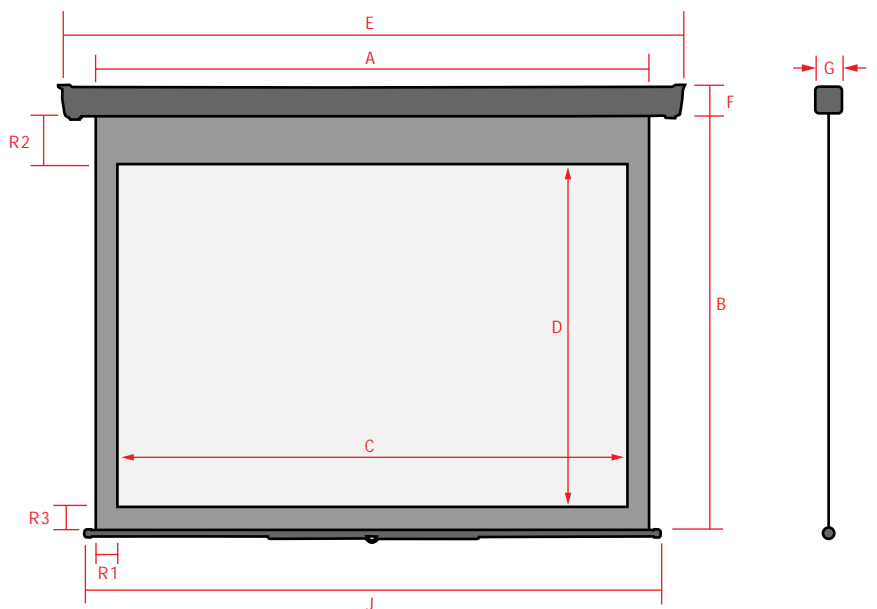

Solid aluminum tube



Plastic end caps for wall or ceiling installation



Warp-resistant profile



Switch of the electric Silverline